

# JOYCE MACHINE SCREW JACKS

15 TON

WJ 815 / DWJ 815  
WJ 2415 / DWJ 2415

Upright

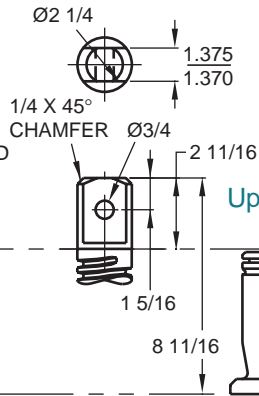
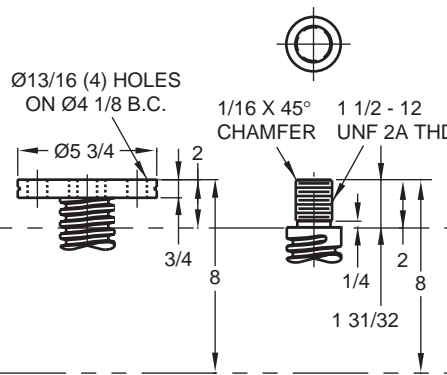
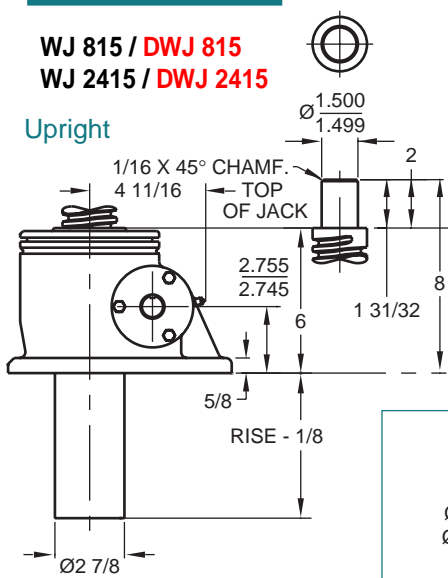

Upright keyed

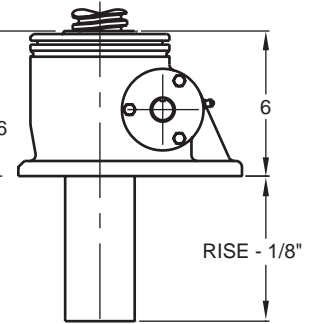

Typical Plan View

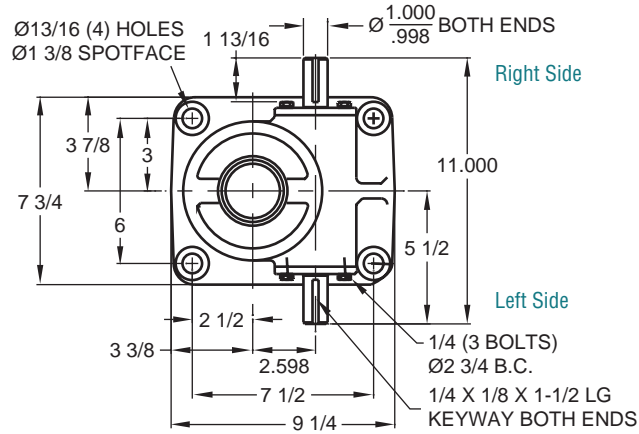

Upright traveling nut

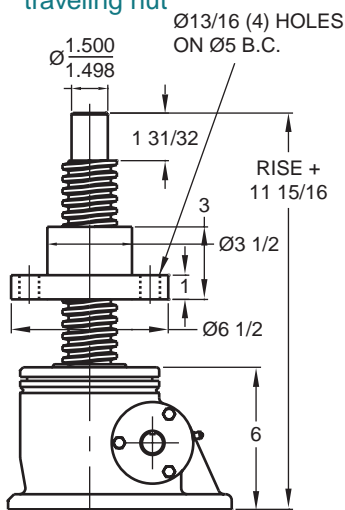

Inverted traveling nut

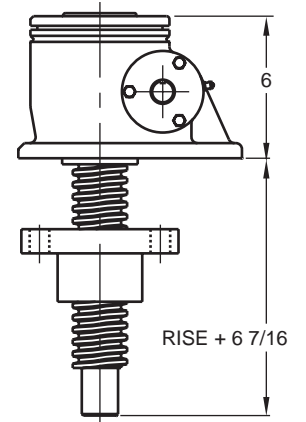

Double Clevis

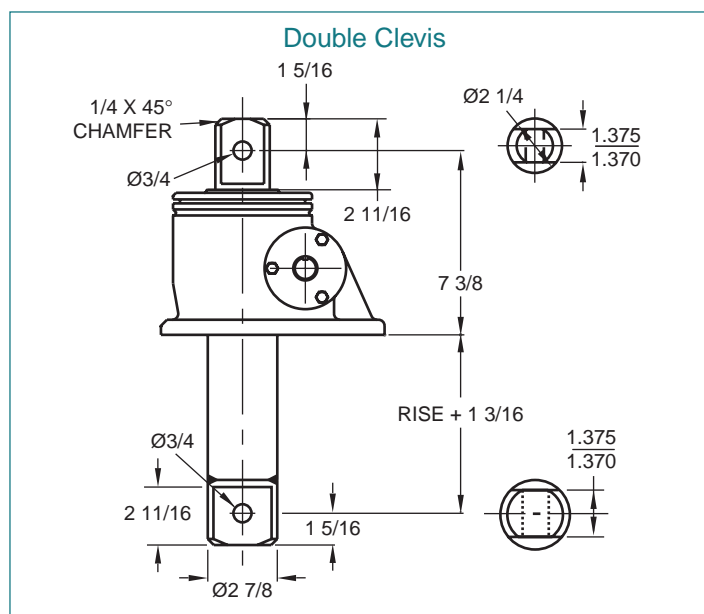

Inverted

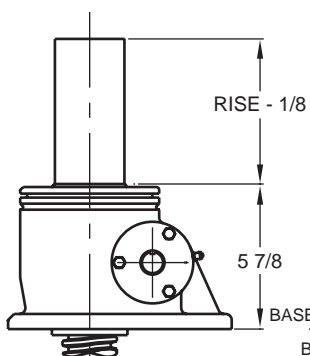

Inverted keyed

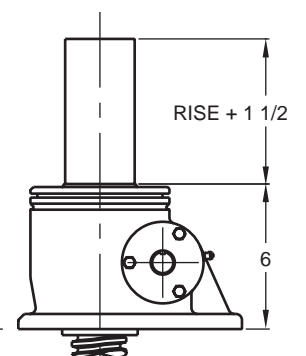

Note: Drawings are artist's conception — not for certification; dimensions are subject to change without notice.