

**CA and CB** 1/2 Ton - CA 1-12 Ton - CB (with or without Capacity Limiter)

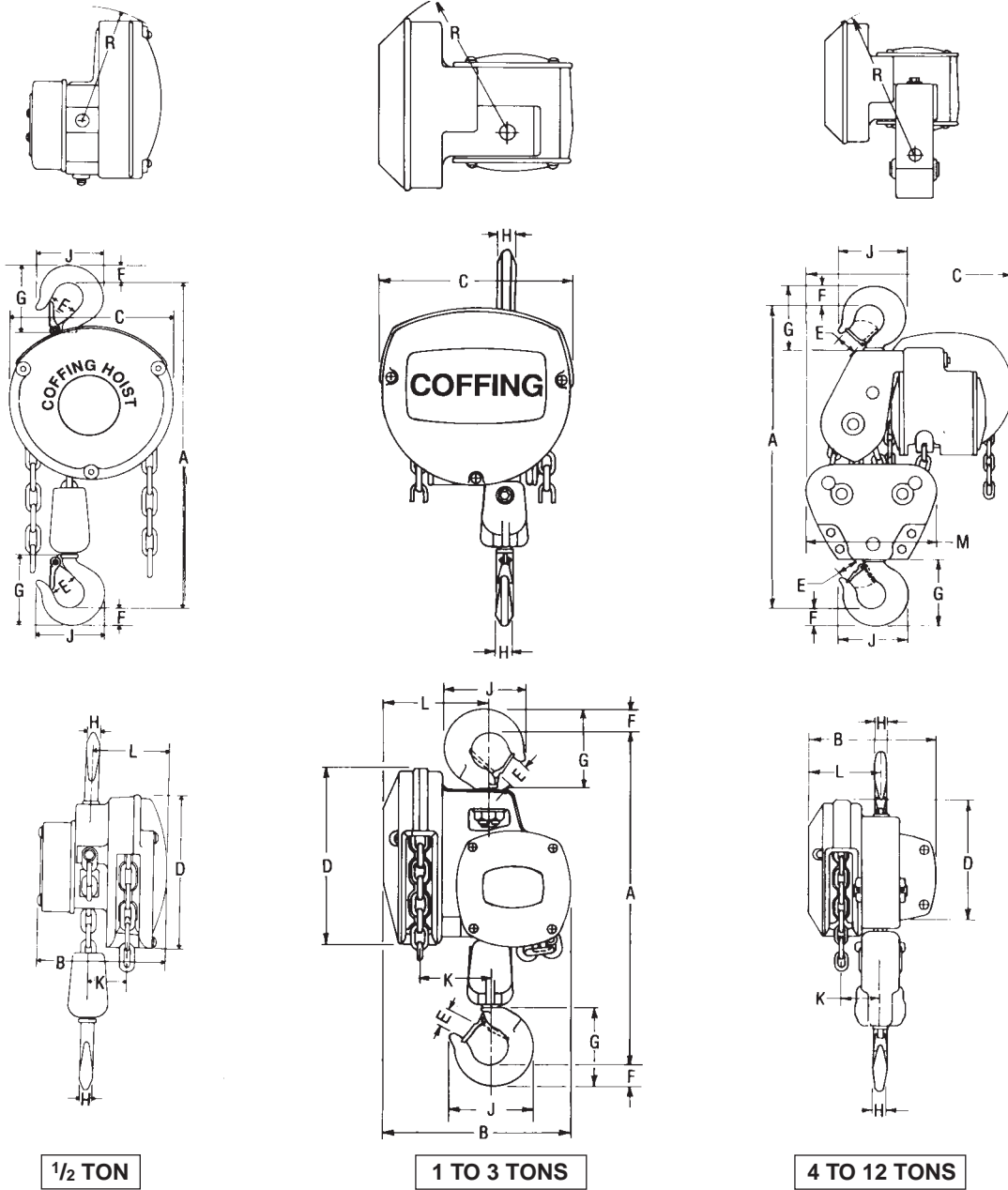

**Dimensions**

Model No.	Rated Load		A	B	C	D	E	F	G	H	J	K	L	M	R
	(Lbs.)	(Ton)													
CA-1/2	1000	1/2	13 <sup>1</sup> / <sub>4</sub>	6 <sup>1</sup> / <sub>2</sub>	8 <sup>1</sup> / <sub>4</sub>	8	1	1	3 <sup>11</sup> / <sub>16</sub>	3/4	3 <sup>5</sup> / <sub>8</sub>	2	3 <sup>15</sup> / <sub>16</sub>	—	6 <sup>1</sup> / <sub>8</sub>
CB-1	2000	1	13 <sup>3</sup> / <sub>8</sub>	9	8 <sup>5</sup> / <sub>16</sub>	8	1	1	3 <sup>11</sup> / <sub>16</sub>	3/4	3 <sup>5</sup> / <sub>8</sub>	3 <sup>3</sup> / <sub>4</sub>	5 <sup>1</sup> / <sub>8</sub>	—	7 <sup>1</sup> / <sub>8</sub>
CB-1 <sup>1</sup> / <sub>2</sub>	3000	1 <sup>1</sup> / <sub>2</sub>	18 <sup>1</sup> / <sub>2</sub>	10 <sup>5</sup> / <sub>8</sub>	10 <sup>3</sup> / <sub>4</sub>	10 <sup>3</sup> / <sub>16</sub>	11 <sup>1</sup> / <sub>32</sub>	17 <sup>1</sup> / <sub>16</sub>	5 <sup>7</sup> / <sub>32</sub>	1 <sup>1</sup> / <sub>8</sub>	4 <sup>15</sup> / <sub>16</sub>	4 <sup>3</sup> / <sub>16</sub>	6	—	9
CB-2	4000	2	18 <sup>1</sup> / <sub>2</sub>	10 <sup>5</sup> / <sub>8</sub>	10 <sup>3</sup> / <sub>4</sub>	10 <sup>3</sup> / <sub>16</sub>	11 <sup>1</sup> / <sub>32</sub>	17 <sup>1</sup> / <sub>16</sub>	5 <sup>7</sup> / <sub>32</sub>	1 <sup>1</sup> / <sub>8</sub>	4 <sup>15</sup> / <sub>16</sub>	4 <sup>3</sup> / <sub>16</sub>	6	—	9
CB-3	6000	3	21 <sup>1</sup> / <sub>2</sub>	12	10 <sup>3</sup> / <sub>4</sub>	10 <sup>3</sup> / <sub>16</sub>	11 <sup>1</sup> / <sub>16</sub>	11 <sup>13</sup> / <sub>16</sub>	6 <sup>9</sup> / <sub>16</sub>	1 <sup>3</sup> / <sub>8</sub>	6 <sup>1</sup> / <sub>2</sub>	4 <sup>11</sup> / <sub>16</sub>	6 <sup>1</sup> / <sub>2</sub>	—	9 <sup>3</sup> / <sub>4</sub>
CB-4	8000	4	25 <sup>1</sup> / <sub>4</sub>	10 <sup>5</sup> / <sub>8</sub>	13 <sup>1</sup> / <sub>16</sub>	10 <sup>3</sup> / <sub>16</sub>	11 <sup>1</sup> / <sub>16</sub>	11 <sup>13</sup> / <sub>16</sub>	6 <sup>9</sup> / <sub>16</sub>	1 <sup>3</sup> / <sub>8</sub>	6 <sup>1</sup> / <sub>2</sub>	4 <sup>3</sup> / <sub>16</sub>	6	5 <sup>1</sup> / <sub>8</sub>	11 <sup>1</sup> / <sub>4</sub>
CB-5	10000	5	26 <sup>3</sup> / <sub>4</sub>	10 <sup>5</sup> / <sub>8</sub>	15	10 <sup>3</sup> / <sub>16</sub>	11 <sup>1</sup> / <sub>16</sub>	11 <sup>13</sup> / <sub>16</sub>	6 <sup>9</sup> / <sub>16</sub>	1 <sup>3</sup> / <sub>8</sub>	6 <sup>1</sup> / <sub>2</sub>	4 <sup>3</sup> / <sub>16</sub>	6	5 <sup>5</sup> / <sub>8</sub>	12
CB-6	12000	6	26 <sup>3</sup> / <sub>4</sub>	10 <sup>5</sup> / <sub>8</sub>	15	10 <sup>3</sup> / <sub>16</sub>	11 <sup>1</sup> / <sub>16</sub>	11 <sup>13</sup> / <sub>16</sub>	6 <sup>9</sup> / <sub>16</sub>	1 <sup>3</sup> / <sub>8</sub>	6 <sup>1</sup> / <sub>2</sub>	4 <sup>3</sup> / <sub>16</sub>	6	5 <sup>5</sup> / <sub>8</sub>	12
CB-8	16000	8	28 <sup>1</sup> / <sub>2</sub>	10 <sup>5</sup> / <sub>8</sub>	16 <sup>7</sup> / <sub>16</sub>	10 <sup>3</sup> / <sub>16</sub>	2 <sup>1</sup> / <sub>16</sub>	2 <sup>1</sup> / <sub>4</sub>	8 <sup>1</sup> / <sub>8</sub>	1 <sup>5</sup> / <sub>8</sub>	7 <sup>9</sup> / <sub>16</sub>	4 <sup>3</sup> / <sub>16</sub>	6	10 <sup>1</sup> / <sub>2</sub>	12 <sup>3</sup> / <sub>8</sub>
CB-10	20000	10	31	12	18 <sup>1</sup> / <sub>8</sub>	11 <sup>1</sup> / <sub>8</sub>	2 <sup>1</sup> / <sub>4</sub>	2 <sup>5</sup> / <sub>8</sub>	9 <sup>1</sup> / <sub>16</sub>	1 <sup>15</sup> / <sub>16</sub>	8 <sup>11</sup> / <sub>16</sub>	4 <sup>11</sup> / <sub>16</sub>	6 <sup>1</sup> / <sub>2</sub>	12	13 <sup>5</sup> / <sub>8</sub>
CB-12	24000	12	31	12	18 <sup>1</sup> / <sub>8</sub>	11 <sup>1</sup> / <sub>8</sub>	2 <sup>1</sup> / <sub>4</sub>	2 <sup>5</sup> / <sub>8</sub>	9 <sup>1</sup> / <sub>16</sub>	1 <sup>15</sup> / <sub>16</sub>	8 <sup>11</sup> / <sub>16</sub>	4 <sup>11</sup> / <sub>16</sub>	6 <sup>1</sup> / <sub>2</sub>	12	13 <sup>5</sup> / <sub>8</sub>

Note: Where clearance dimensions are critical, request certified prints. Dimensions are in inches unless otherwise indicated.